

Elephant Pop-up

By Jeremy Shafer ©2005

Who needs the circus?! Fold this Pop-up model, and have your very own elevating elephant at your fingertips.

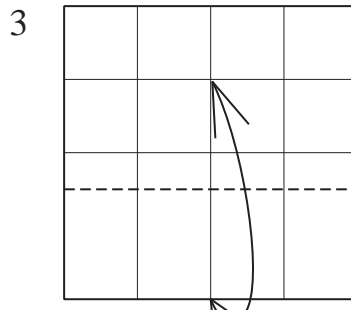
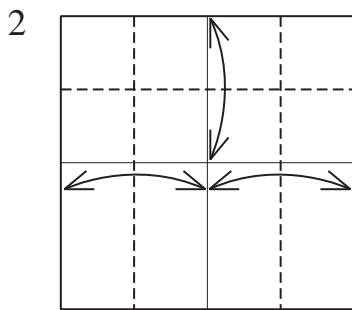
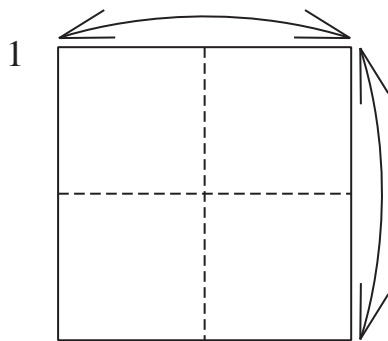
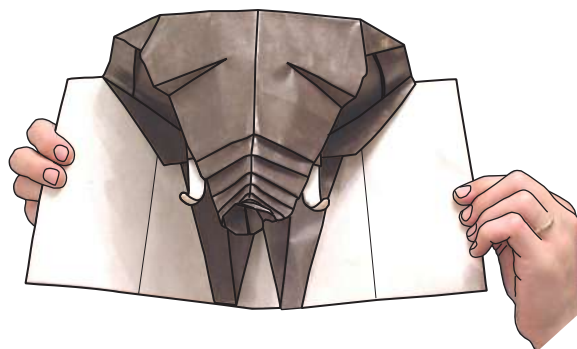

A 16-inch square will make a 4-inch square card (when closed). White side up, valley-fold and unfold.

Valley-fold and unfold.

Valley-fold and unfold.

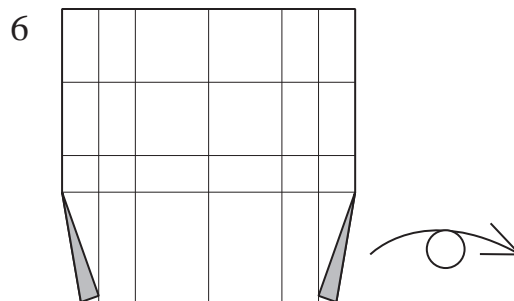
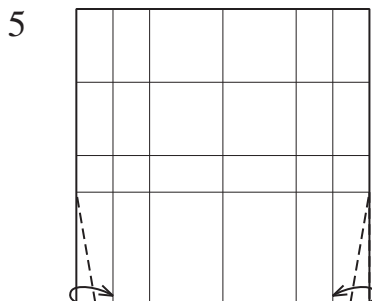
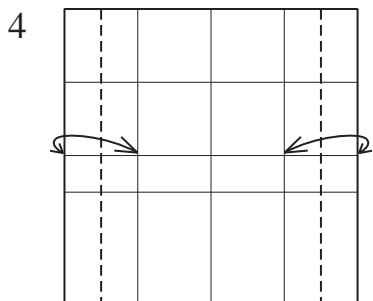

Valley-fold and unfold.

Valley-fold and don't unfold!

Turn over.

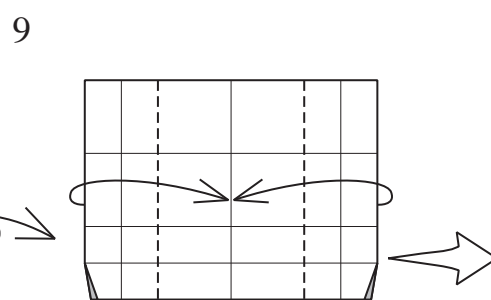
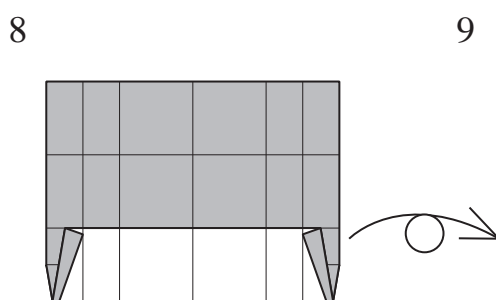
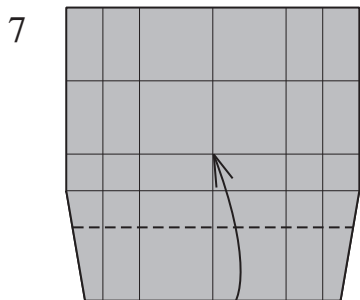

Valley-fold.

Turn over.

Valley-fold.

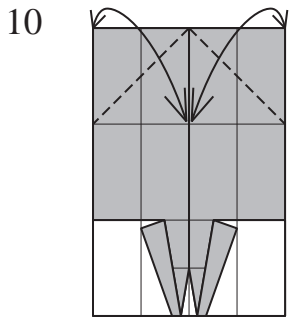

Valley-fold and unfold.

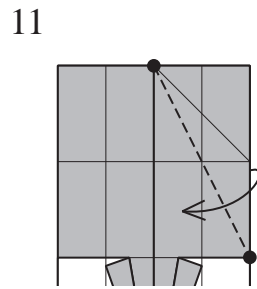

Valley-fold between the black dots.

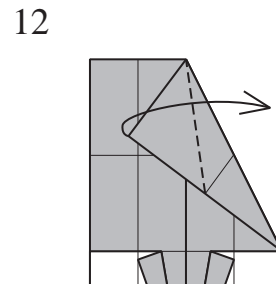

Valley-fold on the existing crease.

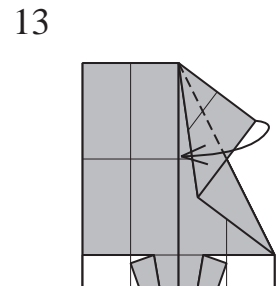

Valley-fold on the existing crease.

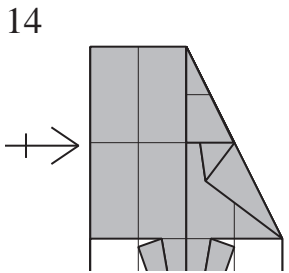

Repeat steps 11-13 on the left side.

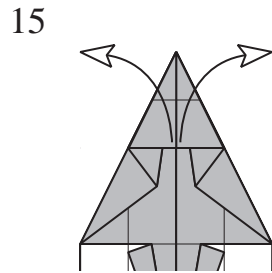

Unfold to step 11.

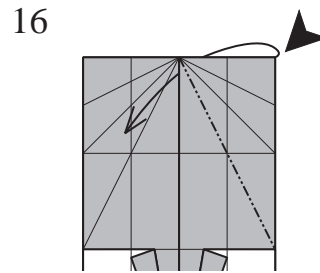

Reverse-fold the right flap on the existing crease and make the flap come out through the middle.

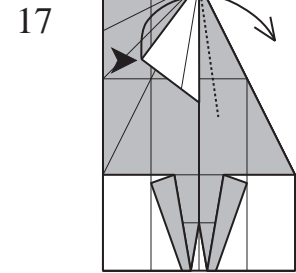

Reverse-fold again on the existing crease.

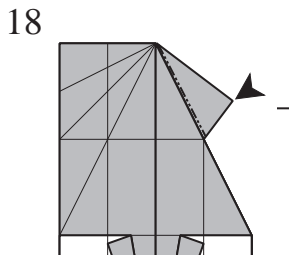

Reverse-fold on the existing crease.

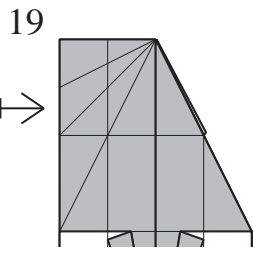

Repeat steps 16-18 on the left side.

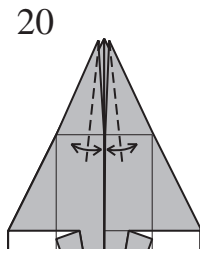

Valley-fold and unfold on the top layer only, using the folded edge on the layer below as a guide.

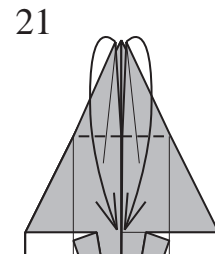

Valley-fold the flaps downward.

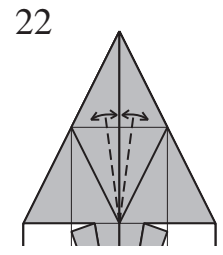

Valley-fold and unfold on the top layer only, as before.

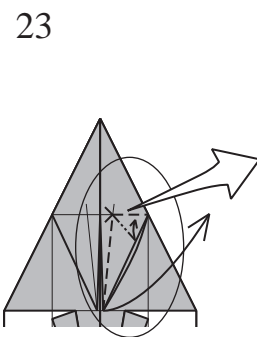

Squash the flap to t in steps 20-22.

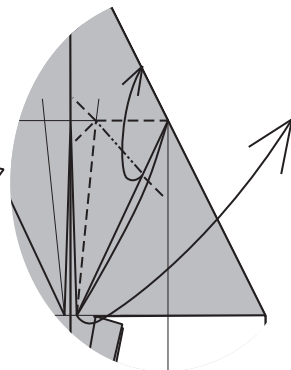

In progress.

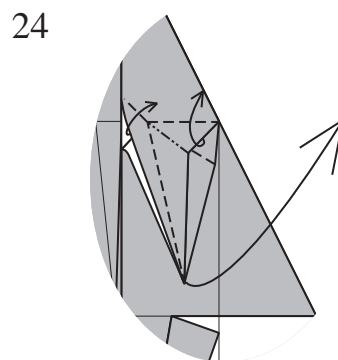

Like this.

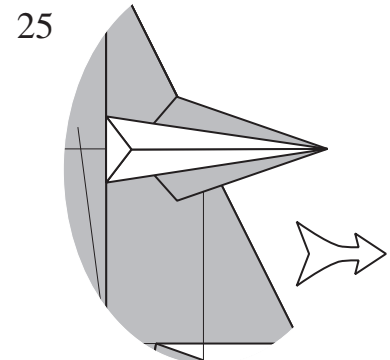

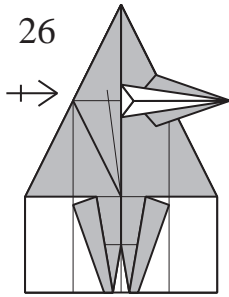

26
Repeat steps 23-25 on the left side.

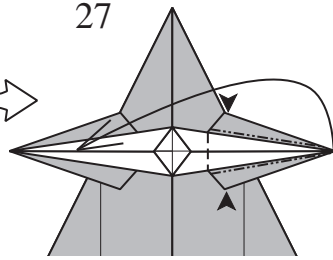

27
Petal-fold the right flap.

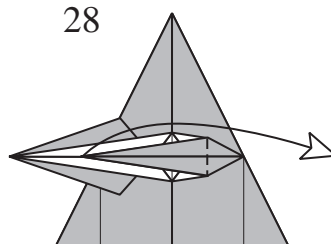

28
Valley-fold.

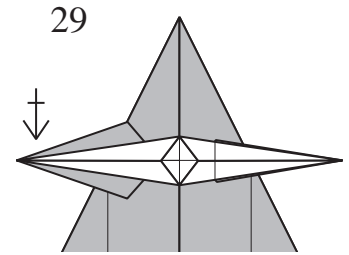

29
Repeat steps 27-28 on the left flap.

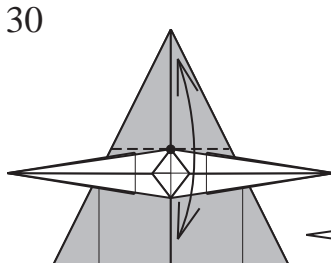

30
Valley-fold and unfold on the black dot.

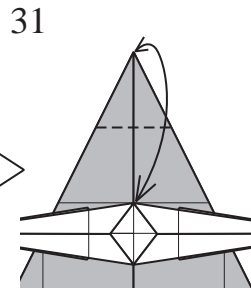

31
Valley-fold and unfold.

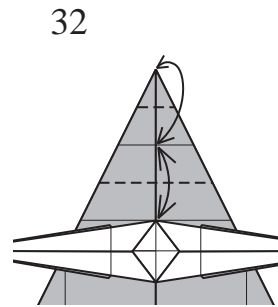

32
Valley-fold and unfold.

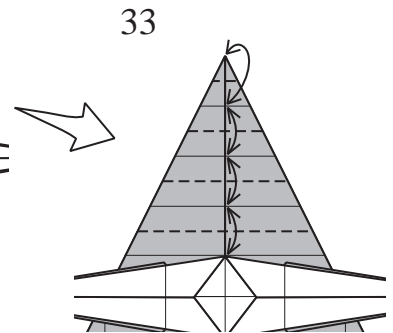

33
Valley-fold and unfold.

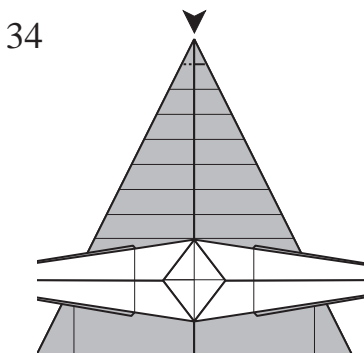

34
Open sink the tip.

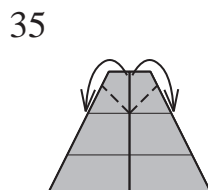

35
Valley-fold, spreading the layers downward.

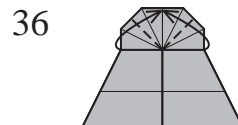

36
Valley-fold the two flaps together.

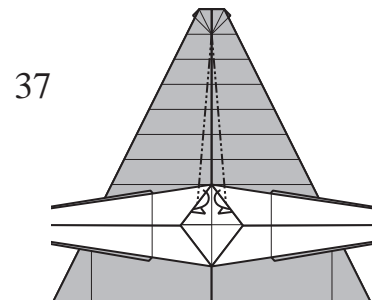

37
Mountain-fold the raw edges behind. The only purpose of this step is to help prevent the paper from tearing in step 45.

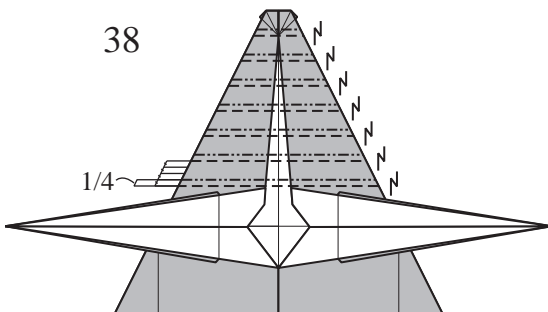

38
Make the indicated pleats using the existing valley creases.

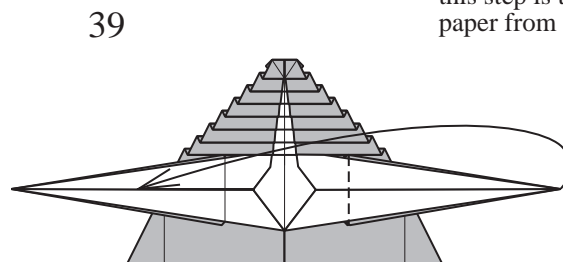

39
Valley-fold the flap leftward.

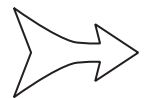

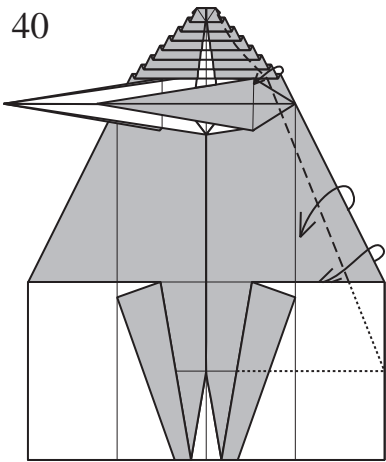

40
Valley-fold as shown. On the lower half of the model, the fold extends underneath the top layer.

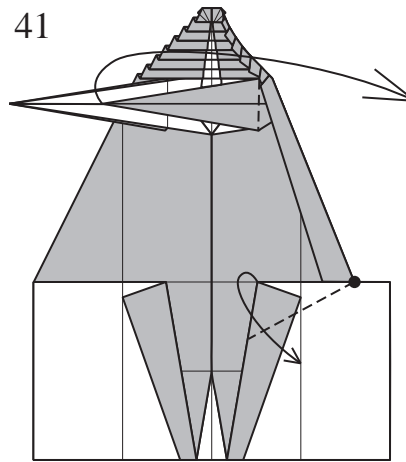

41
Valley-fold the top flap to the right. Valley-fold on the black dot so that the corner touches the existing crease.

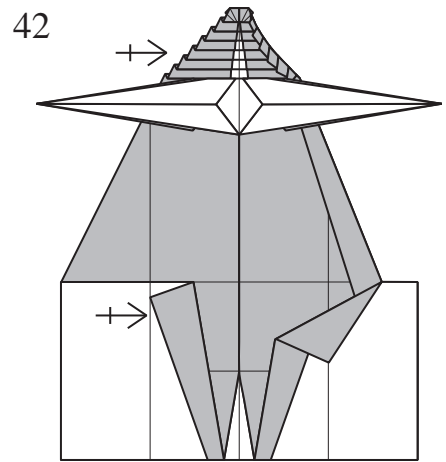

42
Repeat steps 39-41 on the left side.

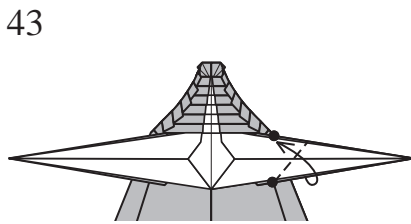

43
Valley-fold the flap so that its lower edge touches the two black dots.

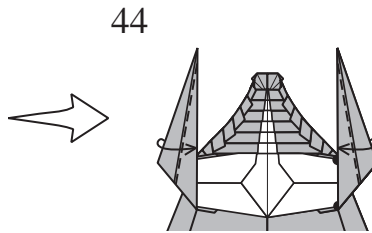

44
Valley-fold.

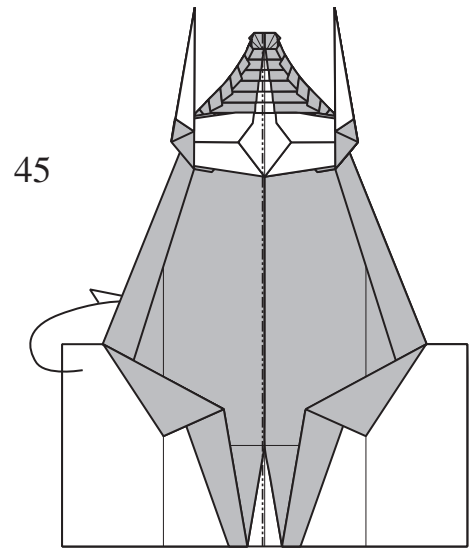

45
Mountain-fold the left side behind.

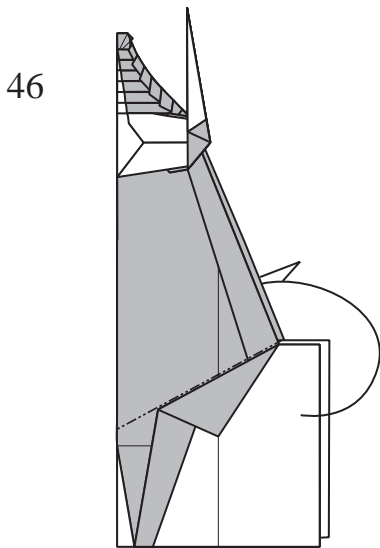

46
Mountain-fold through all layers.

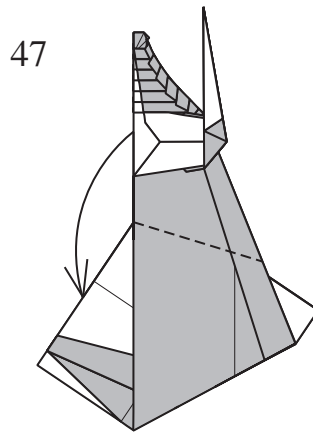

47
Valley-fold edge-to-edge.

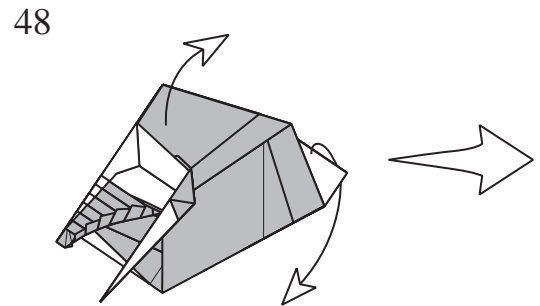

48
Unfold to step 46.

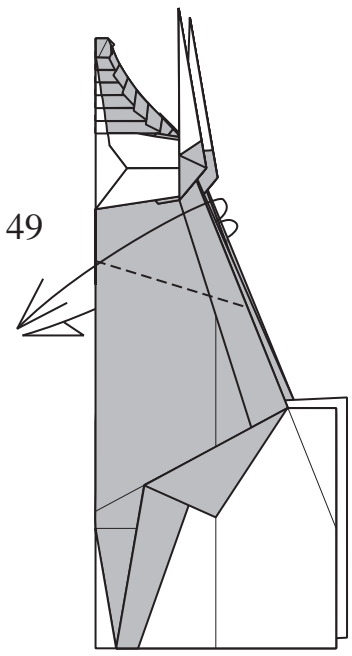

49

Outside-reverse-fold on existing creases.

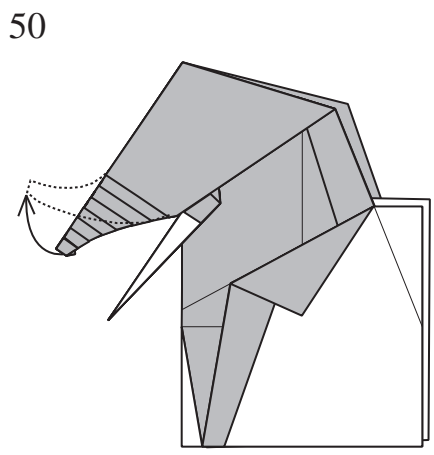

50

Bend the trunk upward, stretching the bottom edge. Be careful not to tear the paper!

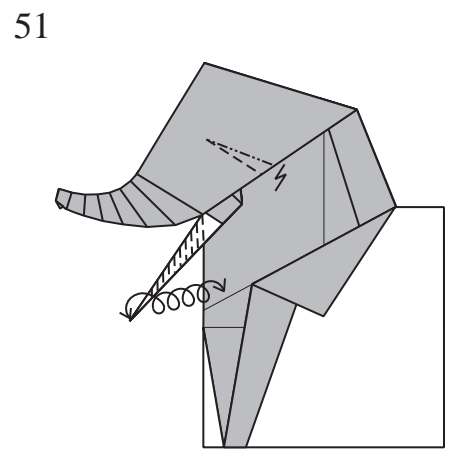

51

Make a pleat to suggest the elephant's eye. Roll and unroll the front tusk forming many vertical valley creases and giving the tusk a natural curvature. Repeat behind.

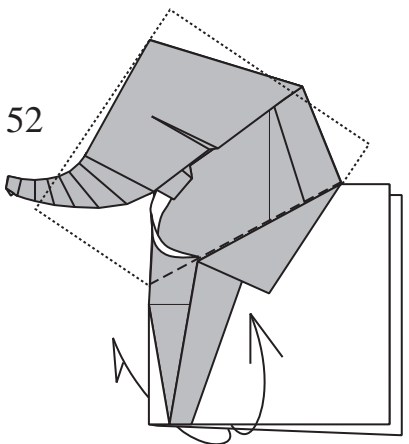

52

Outside-reverse-fold on existing creases.

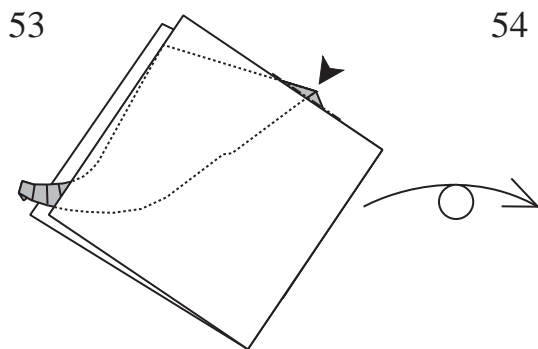

53

Reverse-fold the top of the ear so that it no longer protrudes. **Turn over.**

54

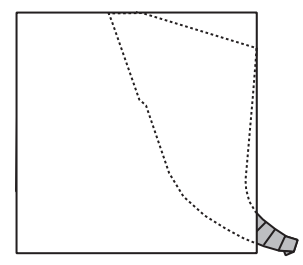

The elephant pop-up is ready to pop up. The trunk sticks out a bit to tantalize the viewer as to what will happen when we open the card...

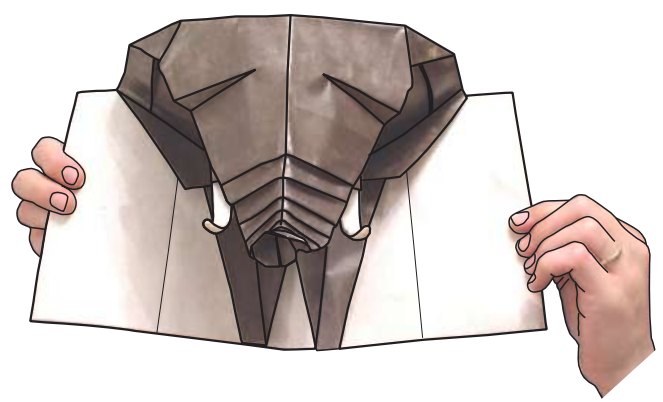

...Pop goes the Elephant!



Pull the left and right sides apart and the elephant lifts its head!